



**Bobcat**®

## 324 Compact Excavator



***One Tough Animal***™

# Specifications 324 Compact Excavator

## General

**324**

Tail Swing Type	Conventional
Tail Swing Overhang	15.1 in. (384 mm)
Operating Weight	3428 lb. (1555 kg)
Dig Depth	8 ft. 6 in. (2.6 M)
Reach @ Ground Level	14 ft. (4276 mm)
Dump Height Clearance	8 ft. 8 in. (2656 mm)
Machine Width	39 - 54 in. (980-1363 mm)
Canopy/Cab Height	85.5 in. (2171 mm)
Ground Pressure	4.2 psi (28.6 kPa)

## Performance

Arm Breakout Force	1778 lbf. (7909 N)
Bucket Breakout Force	3620 lbf. (16102 N)
Rated Lift Capacity (over blade, ground level, 10 ft. (3m) reach)	1031 lb. (468 kg)
Travel Speed (Low range)	1.5 mph (2.5 km/hr.)
Travel Speed (High range)	2.5 mph (4.0 km/hr.)

## Engine

Horsepower	13.9 hp (10.4 kW)
Engine Type	Diesel
Fuel Tank Capacity	6.3 gal (23.7 L)

## Hydraulics

Piston Pump	Yes
-------------	-----

## Machine Features/Options

Enclosed cab with heat	Opt
Radio Ready Enclosed Cab	Std
In-Cab Pattern Selector	Std

## Features for Attachments

Auxiliary Hydraulics	Std
Auxiliary Hydraulic Flow	7.9 gpm (30 L/min.)
Auxiliary Hydraulic Pressure	3248 psi (224 Bar)
Hydraulic Clamp	Opt

## Reach far, dig deep, and outperform.

Reach farther and dig deeper with the 324. Its 8 ft. 6 in. dig depth and 14 ft. reach deliver serious digging possibilities in tight areas, with minimal repositioning. Hydraulically retract the undercarriage to only 39 inches to travel through gates or between homes, and then expand to 54 inches for a wider footprint and greater performance. Equipped with the same hydraulic system as a larger Bobcat excavator, the 324 has impressive cycle times and break-out forces to complete jobs faster.

The system's torque-limiting piston pump is able to sense and react to hydraulic loads, for better utilization of the engine's torque curve.

### Key features and benefits include:

- Cylinder-Over-Boom Work Group
- 13.9 hp liquid-cooled diesel engine
- Auxiliary Hydraulics with Quick Couplers
- Roomy, comfortable operator area
- Hydraulically Retractable Undercarriage
- Self Storing Blade Extensions

NOTE - Where applicable, dimensions are in accordance with Society of Automotive Engineers (SAE) and ISO standards. Specifications and design are subject to change without notice. Pictures of Bobcat units may show other than standard equipment. All dimensions are given for loader equipped with standard tires. All dimensions are shown in inches. Respective metric dimensions are enclosed by parentheses. Bobcat Company complies with the requirements of ISO 9001 as registered with BSI.

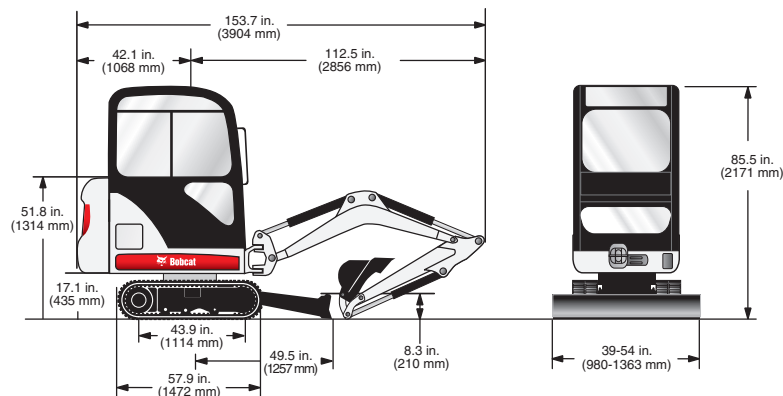

**Bobcat**®

Bobcat Company • P.O. Box 6000 • West Fargo, ND 58078

**Bobcat Attachments for this model:**

- Auger
- Breaker
- Bucket, Trenching
- Bucket, Grading
- Hydraulic Clamp